

# U-Line™ Factory Sealed 20 Amp Panel Mounting Receptacles

## Explosionproof, Dust-Ignitionproof, Watertight

125 Vac, 20 Amp, 1 HP; 250 Vac, 20 Amp, 2HP. Dead-Front Safety Construction.

### NEC/CEC:

Class I, Division 1 and 2, Groups B, C, D

Class II, Division 1 and 2, Groups F<sup>⓪</sup>, G

Class III

NEMA <sup>⓪</sup> 3, 3S, 3R, 3RX<sup>▼</sup>, 4, 4X<sup>▼</sup>, 7BCD, 9F<sup>⓪</sup>G,

12

### Applications

- Class I, Division 1 applications require a minimum of five full threads of engagement (seven for Group B).
  - ECHT is designed to be used where unit is threaded into 1-1/2" NPT (tapered) threads, such as in panelboards.
  - ECH is designed to be used where the unit is threaded into 2" NPSM (straight) threads.
- In Class I, Division 2 applications no thread engagement is required unless non-factory sealed devices are also installed in the enclosure.
  - ECHT and ECH are suitable for use with approved enclosures having threaded or non-threaded openings for these receptacles.
  - Where threaded enclosures are used, they must have 1-1/2" NPT or NPSM threads to fit the ECHT and 2" NPSM (straight) threads to fit the ECH.



### Features

- Furnished with steel locknut and neoprene sealing gasket.
- Gasketed construction protects receptacle against moisture and dirt with plug in or out.
- Interior switch cylinder has neoprene O-ring at each end to seal out dust and moisture.
- Style 2 (shell and extra pole) grounding.
- NEMA 3RX spring-loaded cover and NEMA 4X screw cover included for application flexibility.

### Standard Materials

- Copperfree (less than 4/10ths of 1%) aluminum

### Standard Finishes

- Epoxy clad-two-coat baked finish

### NEC/CEC Certifications and Compliances

- UL Standard: UL 1010 (UL 1203)
- UL Listed: E10784
- CSA Standard: C22.2 No. 25, C22.2 No. 30, C22.2 No. 159
- CSA Certified: 038644

### Recommended Enclosure Types



Typical Class I, Division 1 Application

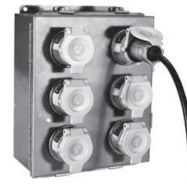

Typical Class I, Division 2 Application

Hazardous (Classified) Location	Suitable NEMA Enclosure Type
Class I, Division 1	NEMA 7BCD with 1-1/2" (1-1/2—11-1/2 NPT) or 2" (2—11 1/2 NPSM) thread opening. Minimum 7 full threads of engagement required for Group B; minimum 5 threads for Groups C and D.
Class I, Division 2	NEMA 3, 3S, 3R, 4, 4X, 12 or any suitable enclosed and gasketed enclosure that prevents the escape of sparks or burning materials.
Class II, Division 1	NEMA 9F <sup>⓪</sup> , G with 1-1/2" (1-1/2—11-1/2 NPT) or 2" (2—11-1/2 NPSM) thread opening. Minimum 3 full threads of engagement required.
Class II, Division 2	NEMA 3, 3S, 4, 4X, 12 or any suitable enclosed and gasketed enclosure that minimizes entrance of dust and prevents escape of sparks or burning materials.

<sup>⓪</sup> Do not use where electrically conductive dusts are present (most coal dusts are not electrically conductive).

<sup>⓪</sup> Suitable for these types with a suitable NEMA enclosure type.

<sup>▼</sup> NEMA 3RX when the spring-loaded cover is installed and closed on a suitable enclosure. NEMA 4X when the screw cover is installed on a suitable enclosure and fully engaged.

# U-Line™ Factory Sealed 20 Amp Panel Mounting Receptacles

Explosionproof, Dust-Ignitionproof, Watertight

125 Vac, 20 Amp, 1 HP; 250 Vac, 20 Amp, 2HP. Dead-Front Safety Construction.

**NEC/CEC:**





Class I, Division 1 and 2, Groups B, C, D

Class II, Division 1 and 2, Groups F, G

Class III

NEMA 3, 3R, 3RX\*, 4X\*, 7BCD, 9FⓄG

## 20 Amp Aluminum Panel Mounting Receptacles

	Thread Size and Type ②	Wire/Pole	Catalog Number	
			125 Vac, 1 HP 	250 Vac, 2 HP 
	1-1/2" (1-1/2—11-1/2 NPT)	2W, 3P	ECHT2023	ECHT20232
	2" (2—11-1/2 NPSM)	2W, 3P	ECH2023	ECH20232

## Dimensions in Millimeters (Inches)

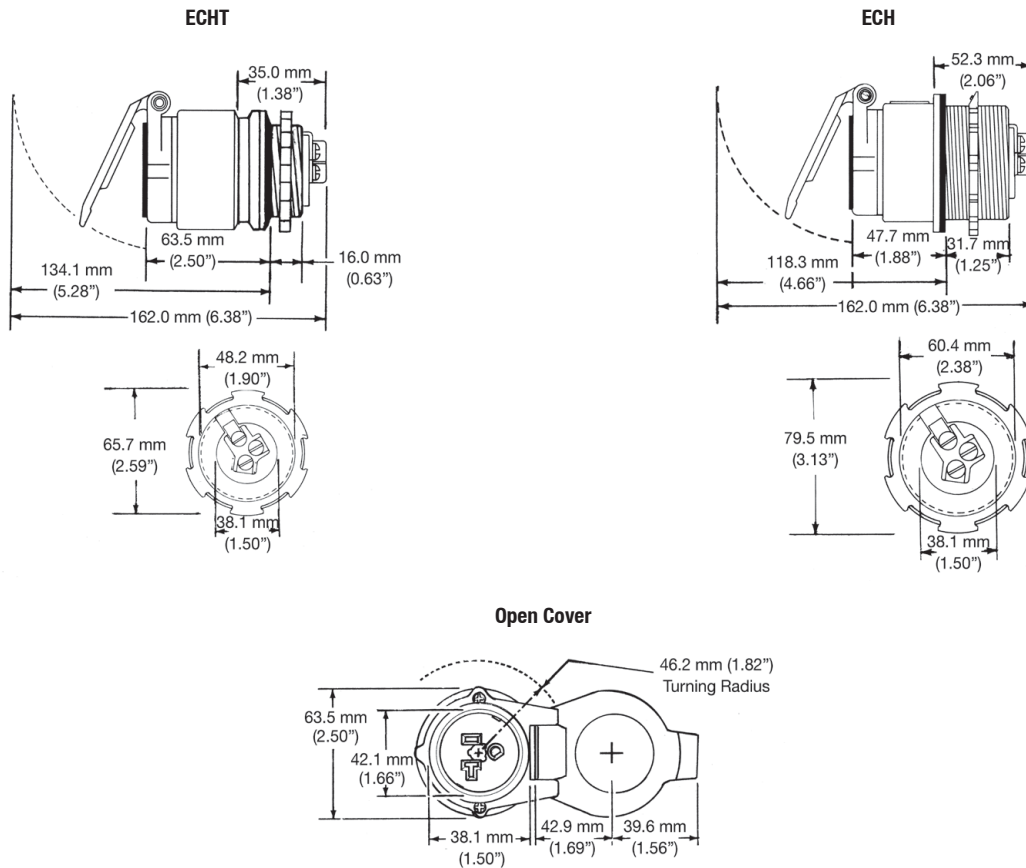

① Do not use where electrically conductive dusts are present (most coal dusts are not electrically conductive).

② ECHT has 1-1/2" tapered threads (1-1/2-11-1/2 NPT); ECH has 2" straight threads (2—11-1/2 NPSM).

▼ NEMA 3RX when the spring-loaded cover is installed and closed on a suitable enclosure. NEMA 4X when the screw cover is installed on a suitable enclosure and fully engaged.